



MØBLER

- A PHILOSOPHY -

Kære Kunde

FDB Møbler er skabt til at give plads til mennesker. En filosofi der har været bøjlet i eg og bøg og flettet ind i sæderne siden 1942. Mange nye designere er kommet til siden, men det grundlæggende er stadig som fra begyndelsen: At frembringe smukke, funktionelle møbler af høj håndværksmæssig kvalitet, som giver plads til det daglige liv i stuerne, køkkenet eller på børneværelset. Og som kan holde til det år ud og år ind. FDB Møbler har for længst skrevet sig ind i dansk designhistorie med klassikere, som er gået i arv gennem generationer.

“Møbler skal helst formes, så man får lyst til at bruge dem. Også om 10 år.”

Quote Foersom & Hjort-Lorezen

Så selv om dit møbel er helt nyt, er det allerede et arvestykke. Fordi det bærer alle de værdier, som vi blev født med og som stadig holdes i hævd. Både når vi producerer vores store klassikere, relancerer møbler fra vores designarkiver eller introducerer helt nye designs, der aldrig før er set. Vi håber, at du bliver glad for din ny erhvervelse. Og at den vil bidrage med al den livskvalitet, som har været tiltænkt, siden vores første møbel voksede ud af tegnebrættet.

• C67 • Butler

Designer Foersom & Hjort-Lorezen

PRODUKTINFORMATION

Butler skrivebord er med sit minimalistiske design skræddersyet til den moderne, nordiske boligindretning. De rene overflader og det lyse egetræ betyder, at bordet kan passe ind de fleste steder og opfylde de mange forskelligartede behov, der gør sig gældende i et moderne hjem i dag. Ikke mindst i de mindre hjem og i lejligheder. Butler er bygget på et solidt håndværk med respekt for den danske designtradition om ærlige materialer og gennemskuelige konstruktioner. Bordet fremstår i et og samme udtryk let og stabilt med en bordplade og et stel, der tilsammen skaber et harmonisk møbel. Butler skrivebord kan fås i to bredder, 120 centimeter og 156 centimeter. Begge er 60 centimeter i dybden. Bordet har en skuffe, der kan sættes i fra begge sider af pladen ud fra, hvad der passer bedst. Den massive bordplade fås også i en lakeret overflade, som gør den modstandsdygtig over for brug og snavs.

Foersom & Hiort-Lorezen

Møbeldesignerne Johannes Foersom (1947-) og Peter Hiort-Lorezen (1943-) går under kunstnernavnet Foersom & Hiort-Lorezen. Sammen har de drevet egen tegnestue siden slutningen af 1970'erne og regnes i dag for "the grand old men" inden for dansk møbeldesign. De arbejder ud fra tanken om det gode og solide håndværk og med en stor vægt på funktionalisme. I det enkle, nedtonede design finder de en æstetisk formgivning, der først og fremmest bygger på funktion og kvalitet. Foersom & Hiort-Lorezen har vundet flere internationale designpriser for bl.a. at udfordre deres arbejde med materialer og finde nye måder at konstruere møbler på, hvilket de er lykkedes med på baggrund af deres håndværksmæssige og akademiske erfaring. Den legende og dynamiske designduo har designet flere møbelserier for FDB Møbler, Gesja, Butler og Mikado, hvor sidstnævnte er en nyfortolkning af Poul M. Volthers ikoniske pindestol J46. Derudover indgår deres møbler i kunstsamlinger på MoMA i New York, Designmuseum Danmark, Trapholt i Kolding, Moderna Museet i Stockholm og Die Neue Sammlung i München.

VEDLIGEHOLDELSE

- Dagligt brug: Som udgangspunkt er FDB Møbler designet og produceret til at indgå i dagligt brug i hjemmet.
- Vedligeholdelse: Med enkel vedligeholdelse vil dit møbel bringe glæde og gavn mange år frem i tiden. Bordet kræver blot beskeden vedligeholdelse, da den er leveret med en lakeret eller malet overflade.
- Den daglige rengøring klares med en hårdt opvredet klud. Det frarådes at bruge rengøringsmidler til den daglige rengøring. Brug kun rent vand.
- Undgå så vidt muligt at placere bordet i direkte sollys, da solens stråler vil mørkne træet.
- Vær opmærksom på at almindeligt lys påvirker træet, og det er derfor helt naturligt, at bordet farvenuance ændres en smule med tiden. Det anbefales derfor at flytte rundt på eventuelle pyntegenstande med jævne mellemrum – for at undgå misfarvninger.
- Vær opmærksom på, at hvis bordet placeres på et blødere trægulv, kan benene efterlade mærker. Dette kan dog let imødegås ved at montere fildupper under bordets ben.



FDB Møbler is manufactured using only FSC-certified wood. FSC certification ensures that no more trees are felled than the forest can reproduce. At the same time, the FSC label guarantees that forest animals and plants are protected, and that the forest workers receive training, safety equipment and a reasonable pay. When you, the consumer, choose FSC, you are helping to protect the natural environment and ensure proper social conditions in the forests where the wood is sourced. In choosing products made with FSC wood, you are supporting forest owners who have chosen to manage their forests in a way that respects the people who work there and the fauna for which the forest is their habitat. For further information, visit www.fsc.dk.



MØBLER

- EN FILOSOFI -

Indhold



Ax10



Bx1

1

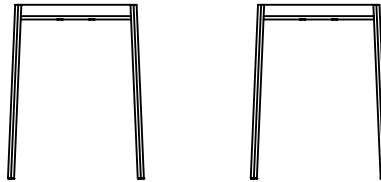
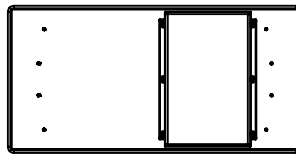

2

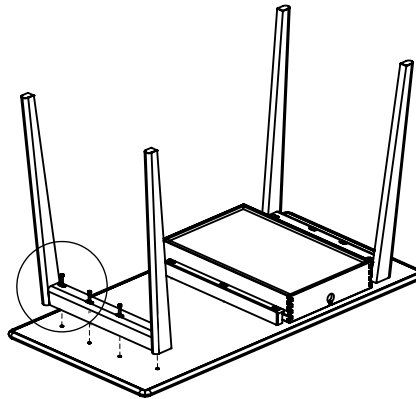
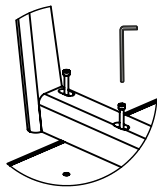

3

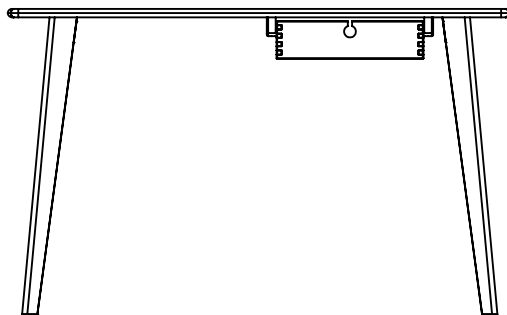



MØBLER

- A PHILOSOPHY -

Dear Customer

FDB Møbler was founded out of a desire to create furniture that makes room for people – a philosophy which has been shaped in oak and beech and woven into seats since 1942. New generations of designers have joined the team since then, but the fundamental mission remains the same: To produce beautiful, functional pieces of furniture made to high standards of craftsmanship that make room for everyday life in living rooms, kitchens and children's bedrooms. And which can withstand wear and tear, year in and year out. FDB Møbler wrote itself into the annals of Danish design history long ago with classics that

“Furniture should preferably be designed so you want to use it. Also ten years from now.”

Quote Foersom & Hjort-Lorenzen

have been passed down for generations. So even if your furniture is brand new, it is already an heirloom, because it is imbued with all the values that we were born with, and which are still honoured to this day when we produce our classics, relaunch furniture from our design archives, or introduce brand-new designs. We hope you will be happy with your new purchase, and that it will enhance your quality of life, as this has been the intention ever since our first pieces of furniture emerged from the drawing board.

• C67 • Butler

Designer Foersom & Hjort-Lorenzen

PRODUCT INFORMATION

The Butler desk is a perfect and minimalist design for modern Nordic interiors. With its sleek design in pale oak, the highly versatile desk will look great in most homes and meet the many and varied needs of modern households. Not least in small homes and flats. Butler is an outstanding example of solid craftsmanship that respects the Danish design tradition of honest materials and transparent construction. The design immediately strikes one as light yet stable and with a harmoniously composed desktop and frame. The Butler desk is available in two widths: 120 cm and 156 cm. Both versions are 60 cm deep. The desk incorporates a drawer which can be inserted from both sides depending on what is most suitable. The solid desktop is also available with a lacquered surface, which is very resistant to wear and tear.

Foersom & Hiort-Lorenzen

The furniture designers Johannes Foersom (1947-) and Peter Hiort-Lorenzen (1943-) are known under the name Foersom & Hiort-Lorenzen. They have run their own design studio since the late 1970s, and are today considered 'the grand old men' of Danish furniture design. They set great store by good and solid craftsmanship in combination with a high degree of functionality. In their simple, toned-down designs, they find an aesthetic idiom that primarily relies on function and quality. Foersom & Hiort-Lorenzen has won several international design awards for, among other things, their innovative approach to working with materials and constructing furniture, which has proved successful thanks to their hands-on and academic experience. The playful and dynamic design duo has designed several furniture series for FDB Møbler such as Gesja, Butler and Mikado, Mikado as a reinterpretation of Poul M. Volther's iconic spindleback chair J46.

In addition, their furniture is on permanent display at MoMA in New York, Designmuseum Denmark, Trapholt in Kolding, the Moderna Museet in Stockholm and at Die Neue Sammlung in Munich.

CARE INSTRUCTIONS

- The table only requires a small amount of maintenance since it comes with a lacquered surface
- Use a slightly damp cloth for daily cleaning. Generally, it is not a good idea to use cleaning agents – just clean water. If a cleaning agent is used occasionally, it is important to dry the surface immediately afterwards with a clean cloth
- Avoid scraping or scratching the surface when cleaning
- In the unlikely event of spillages, immediately wipe up the spillage with an absorbent, colourfast cloth.
- Avoid placing hot objects such as tea-lights directly on the wood
- Please note that ordinary light affects the wood, and therefore the colour of the wood will naturally change slightly over time. In so far as possible, avoid placing the table in direct sunlight, as the sunshine will darken the wood. It is therefore a good idea to move any decorative objects around at regular intervals to avoid discoloration.
- Please note that the legs may leave marks on soft wooden floors. However, this can easily be prevented by putting felt pads under the legs.



FDB Møbler is manufactured using only FSC-certified wood. FSC certification ensures that no more trees are felled than the forest can reproduce. At the same time, the FSC label guarantees that forest animals and plants are protected, and that the forest workers receive training, safety equipment and a reasonable pay. When you, the consumer, choose FSC, you are helping to protect the natural environment and ensure proper social conditions in the forests where the wood is sourced. In choosing products made with FSC wood, you are supporting forest owners who have chosen to manage their forests in a way that respects the people who work there and the fauna for which the forest is their habitat. For further information, visit www.fsc.dk.



MØBLER

- EN FILOSOFI -

Indhold



Ax10



Bx1

1

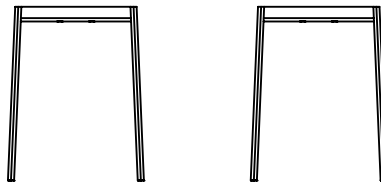
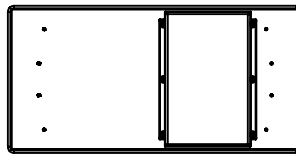

2

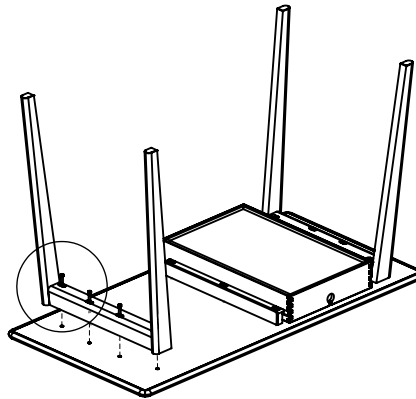
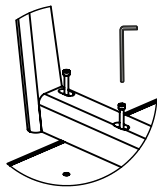

3

